



SERIES



KANGA MULTI-TASK COMPACT SKID STEER LOADER

KANGA KEY FEATURES

- 1 Self Levelling Bucket
Kanga's buckets ensure safe,fast, easy operation without the danger of load spillage over the operator - making it the only Mini Loader in today's market with this feature.
- 2 Bucket Roll Back
Kanga's better bucket design makes it easier to capture a full load and minimizes spillage while travelling. Excellent roll back and dump angles make filling the bucket fast, easy and efficient. Travelling safely with the bucket fully lowered at the lowest centre of gravity (with the arms fully against the machine chassis) allows quicker cycle times.
- 3 Machine Balance
Superior design enables loader to remain balanced either fully loaded or bucket removed.
- 4 Oil Safety Cutout Switch - Petrol only.
- 5 Auto Auxiliary Cut Out
Larger operator platform, wider stance for improved safety and fatigue reduction - Shuts down auxiliary power should operator leave machine.
- 6 Safety Relief Valve
Prevents operator from overloading the machine.
- 7 Simple Controls & Ergonomic Design
Kanga's soft touch controls are smoother to use - this enables the operator to reach less and be more productive. The simple and easy to understand controls help minimise operator fatigue.
- 8 Enclosed hydraulic wheel motors
Prevent damage, yet easily accessible.
- 9 Four Hi-torque hydraulic wheel motors
Giving you increased performance when breaking ground and trenching.
- 10 No Counter Weights
Best design by industry standards. Excellent weight distribution improves ground penetration and digging through the elimination of rear counterweights. (The use of counterweights reduces downward cutting pressure at the cutting edge, severely limiting digging ability bucket and post hole work).
- 11 Rupture Resistant Fuel Tanks
Twin long range (50L), heavy gauge steel fuel tanks allow up to 3 days operation and less re-fuelling down time.
- 12 Long Life Linkage Pins
Greasable pins with hardened steel bushes.

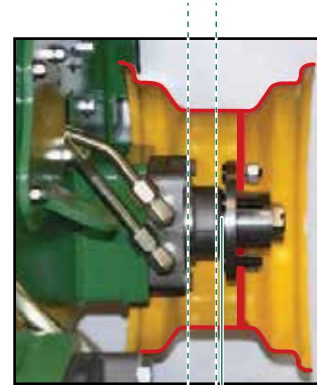

Bearing centre line.
Wheel centre line
Shaft seal protected inside wheel



23" Lug Skid Steer Tyres

Load Engineering

All machinery needs engineering strategies to place the least possible load and stress on its components. Not all skid steer loaders are engineered the same. Kanga Loaders are engineered to perform and to last.

- No overhung load. Design allows wheel load to be placed directly over bearings resulting in the longest possible service life.
- Zero overhang helps protect against seal damage from stringy weeds, stringy bark mulch and string entanglement preventing unnecessary maintenance and premature seal failures.
- Simple well designed wheel motor installation allows for quick and simple servicing and wheel motor removal/replacement.
- This Kanga design ensures long life and minimal maintenance - Keeps you working longer.

The Wheel Story

Never misunderstand the importance of wheel/tyre combinations on earthmoving equipment. Often this critical point is overlooked by the prospective buyer/operator. Kanga has addressed the critical importance of wheels and tyres on earth moving machinery.

Kanga's basic model line-up is complimented by the best wheel/tyre ground clearance combo possible.

- Best ground clearance
- Biggest wheel tyre combination
- No compromise on torque (pushing power)
- Strong heavy duty wheel construction
- Best in Class - Approach and departure angles
- Best in Class - Load carrying stability across undulating ground

Larger Operators Platform - allows for wider stance for improved safety and fatigue reduction.



Safety Relief Valve - The lift circuit is set at 2400psi to protect the operator from overloading the machine.

Safety Cell - Operator enclosed within operating platform. Bump protection on tanks also provides additional support when on rough terrain.



Stability carrying the load with generous bucket rollback - Easy filling and safe transportation without load spillage, arms fully lowered (lower centre of gravity).

Safety Auxiliary Cut Out - Auxiliary hydraulic flow will neutralize when no operator is present



Oil Safety Cut Out Switch - The mercury switch sensor detects low oil level and immediately shuts off to protect the engine.



Over the past 34 years Kanga's vision and core focus has always been based upon innovation and customer safety. The Kanga Klean program brings both of these elements together. This market innovation has been researched and developed extensively by Kanga with astounding results in reducing diesel particulate matter and carbon monoxide emission, without compromising performance.

At Kanga we make it our business to understand yours

To hit your numbers you need equipment that is safe, reliable, rugged and easy to operate and maintain. Kanga equipment has been designed to enhance your bottom line, and we back it with one of the most comprehensive sales and service networks in the industry.

Custom Packages

Ask about our industry specific packages that are tailor built to give you the leading edge in your industry.



Over 70 attachments

A vast selection of attachments are available for the Kanga 7 Series enabling your skid steer to be used in most situations to get the job done quickly and with a minimum of fuss.

Attachments available include

- | | | |
|------------------------|-------------------|-------------------|
| 4 in 1 Bucket | Cement Mixer Bowl | Front Hoe |
| Trencher | Dozer Blade | Rubble Bucket |
| Rotary Tiller | Forks | Turf Cutter |
| Auger Drive | Rock Grab | Tow Hitch |
| Augers 150mm to 750mm | 2 & 3 Tyne Ripper | Hydraulic Breaker |
| Carryall Leveller | Mulch Bucket | Debris Puller |
| Under Road Borer | Log Splitter | Cattle Yard Broom |
| Multi-Purpose Tool Bar | Power Rake | Grapple Bucket |
| Bucket Broom | Lawn Aerator | Vinyl Stripper |

Since inventing the mini loader in 1980, Kanga have continued to lead the industry in SAFETY, INNOVATION and PERFORMANCE. Australian owned and built, Kanga adheres to government guidelines for Workplace Health and Safety and operates under World's Best Practices incorporating H.A.V. (Hand Arm Vibration) standards as well as internationally recognized Risk Management studies and procedures.

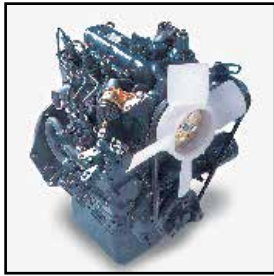

Kubota

25hp D902-E

Three cylinder water cooled engine featuring Kubota's original Triple Vortex Combustion System Indirect Injection (E-TVCS). EPA Certified.

Highly reliable, sturdy design delivers long service life with advantages to meet any application.

Kubota's E-TVCS Indirect injection Combustion System keeps noise levels to a minimum.

Kubota engines exceed the requirements of EPA.

Super Glow system comes standard to shorten pre heat time and quicken engine starting in cold weather.

A sturdy, truly industrial engine with gear driven top end and cams.

Kubota is known around the world as a manufacturer of top quality diesel engines. With it's outstanding technical experience, untiring research and deep concern for the environment, Kubota developed the world's smallest, multi density diesel engine series, the SUPER MINI in 1983 and has since then maintained it's popularity by continuing to deliver powerful, highly dependable engines.



HONDA
28hp GX690

The new Honda V Twin engine offers more power for less fuel consumption, is one of the quietest petrol engines available and is well suited for the rigorous demands of the earth moving environment.

Honda's renowned reliability ensures consistent trouble free operation.

- Fuel Efficient Operation
- High Output Performance
- Reliable
- Easy to Use and Maintain
- Quiet
- Easy Start

- 1 Oil Cooler Maintains oil temperature for optimal performance.
- 2 Trenching Valve Controls the flow from attachments to wheels - Set and forget, excellent for trenching.
- 3 Colour Customise your machine colour to match the rest of your fleet/corporate colours.
- 4 5"Donaldson Air Cleaner High quality air filter used on top quality construction equipment. Full view plastic bowl lets operator easily see when service is needed - industry best (Standard on Diesel Models).
- 5 Remote Key Switch Ergonomic design - Taking into consideration operator comfort. Comes standard with Oil Pressure, Charge Lights and Hour Meter.
- 6 Choke Ergonomic design - Taking into consideration operator comfort.
- 7 Horn - A warning noise made when you press it - often required for OH&S purposes.
- 8 Headlights - A light with a reflector and lens mounted at the front of the machine.
- 9 Handbrake - A park brake operated by hand (Extra safety brake).
- 10 Spare Wheel Bracket - A location to carry your spare wheel in case of puncture when on site.
- 11 Emergency Stop Button Shuts down the machine functions in the event of an emergency.
- 12 Reverse Beeper - A sound device fitted to alert personnel of a reversing machine.
- 13 Back Protection Bars - An extension of the safety cell - used to encapsulate the operator when operating in a confined space. Protects the rear of the machine from unnecessary damage.
- 14 Case Drain Kit Drains the pressure from the attachment motor - Ideal for the Hydraulic Stump Grinder and Vibrating, Plough attachments.
- 15 Battery Isolator Switch Enables the machine to be locked out - Provision for a padlock available.
- 16 Stop Light - A light at rear of the machine that is activated when the machine is at idle or operator hands are removed from levers.
- 17 Flashing Light - An amber beacon used for safety purposes.
- 18 Rear Dig Legs - A set of rear legs fitted to the machine in order to stabilise & increase the down pressure when augering and drilling.
- 19 Honda GX690 Petrol Engine Fuel Efficient Operation / Emissions Compliant / High Output / Smooth Performance / Easy to Start, Use & Maintain / Exceptionally Quiet / Reliable / 3 Year Limited Warranty
- 20 Kubota Diesel Engine Lightweight / Compact / EPA Certified / Reliable / Low Noise / Robust Industrial Design

34 YEARS OF INNOVATION

Since being established in 1978 as Jaden Engineering the Kanga Loader has been a source of innovation in the multi-task compact skid steer market. Starting with the original idea and prototype in 1980 and developing through with the first production model in 1981 Kanga have been constantly setting the standard higher.



1978



1980



1981



1984



1985



1986



1988

1978

The Original idea - a motorized wheel barrow

1980

The First Prototype a walk behind, slow and awkward

1981

The First Prototype a walk behind, slow and awkward

1984

First Maxi Prototype originally called the Dingo 1000

1985

Jaden Maxi only 3 cyl, 22hp Kubota Diesel Engine.

Manufacturing rights illegally sold, resulting in renaming to the Jaden Loader

1986

Mk1 a major design revision adding horse power with improved poise and balance

1988

2 Series - long range fuel tanks beginning to be developed

1989

3 Series - long range fuel tanks, standard colours

Awarded the Australian International Design Award

1996

4 Series - First Model with 10" wheels & larger fuel tanks

1997

Renamed as the Kanga with the start of export to North America & New Zealand

1999

24HP Vee Twin Engines introduced to the 4 Series

2000

5 Series - an evolution from the 4 Series with safety leading to auto AUX cutout

Kanga Kid Mini Skid Loader, introduced the smallest on the market

2002

The Kanga Kid Track Mini Skid Loader released - the smallest track machine in the world

2004

6 & 7 Series released

Finalist Australian Export Award

Winner Premier of Queensland Export Award

2006

25HP 2 Speed 8 Series released, the largest and most powerful model in the range

2007

Highly Commended, Innovative Product of the Year; Manufacturing - Endeavour Award, Manufacturer's Monthly

5-6-7-A Series updated to 4 wheel motors, wider platform increasing performance and comfort

2008

Commenced development of the Kanga Remote Loader and first prototype released

2009

Kanga was acquired by Digga Australia

2010

Kanga Warrior was released

2011

Kanga Remote Loader re-released

2013

Kanga Midi Range Loader released

2014

Kanga release the Kanga Klean program which is an industry first in emissions reduction



2014



2013



2011



2010



2007



2004



2002



1989



1996



1999



2000

| PERFORMANCE | PW628 | | DW625 | |
|--|--------------------------------|------------------|--------------------------------|----------------|
| Max. Lift Capacity | 250 kg | 551 lbs | 250 kg | 551 lbs |
| Breakout Force at Tip of Standard Bucket | 489 kg | 1078 lbs | | |
| Travel Speed | 7 km/h | 4.3 mph | 7.5 km/h | 4.7 mph |
| Operating Weight (Machine Only with water filled tyres) | 875 kg | 1929 lbs | 972 kg | 2138 lbs |
| Fuel Capacity | 45 L | 11.8 gal | 45 L | 11.8 gal |
| Fuel Type | Unleaded or Premium Unleaded | | Diesel Fuel | |
| ENGINE | PW628 | | DW625 | |
| Manufacturer | Honda GX690 | | Kubota D902 | |
| Net Power (SAE Class J1349) | 16.5 kW | 22.1 hp* | 17.5 kW | 23.5 hp* |
| Gross Power (SAE Class J1995) | 20.8 kW | 28 hp* | 18.5 kW | 25 hp* |
| Max Torque | 48.34 Nm | | 56.0 Nm | |
| DRIVE SYSTEM | PW628 | | DW625 | |
| Drive Control | Soft Touch Hand Levers | | Soft Touch Hand Levers | |
| Throttle Control | Hand Levers | | Hand Lever | |
| Wheels | Direct Drive Hydraulics Motors | | Direct Drive Hydraulics Motors | |
| Tyres | 23" Lug Tyres Water Filled | | 23" Lug Tyres Water Filled | |
| HYDRAULICS | PW628 | | DW625 | |
| Gear Pump Displacement | 11.3 cc/rev | 0.69 cu.in/rev | 12.5 cc/rev | 0.76 cu.in/rev |
| Pump Output | 41 L/min | 10.75 US gal/min | 45 L/min | 11.9 USgal/min |
| System Pressure | 207 bar | 3000 psi | 220 bar | 3200 psi |
| Hyd. Reservoir Capacity | 70 L | 17.4 US gal | 70 L | 17.4 US gal |
| BUCKETS | PW628 | | DW625 | |
| Standard & 4 in 1 Bucket Capacity | 0.1 m ³ | 3.5 cu.ft | 0.1m ³ | 3.5 cu.ft |
| DIMENSIONS | PW628 | | DW625 | |
| A Max Operating Height | 2500mm | 98.4" | 2500mm | 98.4" |
| B Height to Hinge Pin | 1855mm | 73" | 1855mm | 73" |
| C Overall Height | 1340mm | 52.8" | 1340mm | 52.8" |
| D Overall Length With Bucket | 2200mm | 86.6" | 2200mm | 86.6" |
| E Overall Wheel Width | 1030mm | 40.6" | 1030mm | 40.6" |
| F Bucket Reach at 40° | 410mm | 16.1" | 410mm | 16.1" |
| Bucket Max Reach (Level) | 1020mm | 40.1" | 1020mm | 40.1" |
| G Dump Height Std. Bucket | 1130mm | 44.5" | 1130mm | 44.5" |
| Dump Height 4 in 1 Bucket | 1855mm | 73.0" | 1855mm | 73.0" |
| H Bucket Width | 1050mm | 41.3" | 1050mm | 41.3" |
| I Bucket Max Roll Back | 40° | | 40° | |
| J Bucket Max Dump Angle | 60° | | 60° | |
| K Ground Penetration | 430mm | 16.9" | 430mm | 16.9" |
| L Overall Length Less Bucket | 1660mm | 65.4" | 1660mm | 65.4" |
| M Ground Clearance | 185mm | 7.3" | 185mm | 7.3" |
| N Angle of Departure | 40° | | 40° | |
| Approach Angle | 90° | | 90° | |



Australian Designed
 Australian Made
 Australian Owned
 Engine Warranty*
 - Diesel 2 Years/Unlimited
 - Petrol 3 Years/Unlimited
 Commercial Product Warranty -
 2 Years/1000hrs*
 *Warranty Conditions Apply



Telephone: 1300-4-KANGA

For the complete range of Kanga Loaders, visit
www.kanga-loader.com

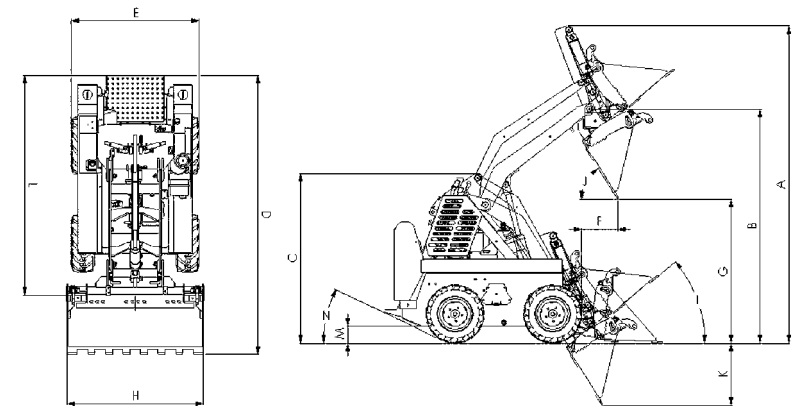

Dealer Stamp

Kanga Loaders WA, U3-204 Balcatta Road, Balcatta WA
 6021 P O Box 910, Balcatta WA 6914. Tel: 08 9240 7844
 ABN: 92288618

* The Power ratings of the engine indicated in this document are the power of the production engine only and are measured in accordance with SAE J 1349 and SAE J1995 at 3600 rpm. Mass production engines may vary from this value, Actual power output for the engine installed in the final machine may vary depending on numerous factors, including operation speed of the engine in application, environmental conditions and other variables.